



Since 1966

Tubular Specialties Manufacturing, Inc.

13011 South Spring Street, Los Angeles, CA 90061-1685
Phone 800/Grab Bar (800/472-2227) or 310/515-4801
www.GrabBar.com • Fax 310/217-0653

S-SH-2

Technical Data

Revised April 2007

Round Concealed Screw Shower Rod Flanges

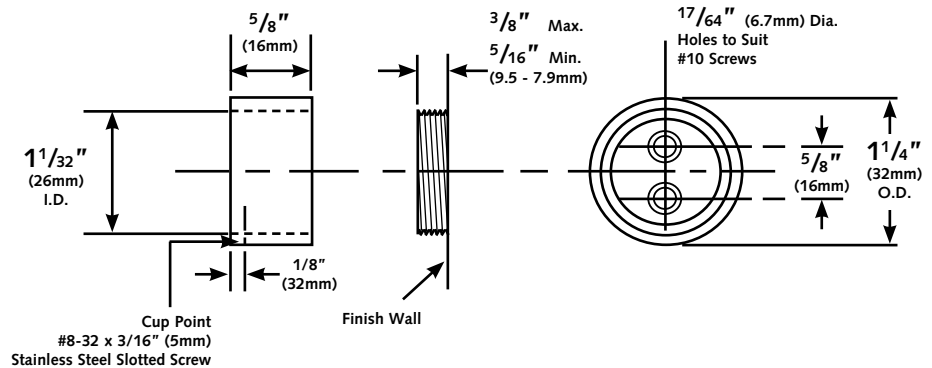

Suggested Architectural Specification

Round Concealed Screw Shower Rod Flanges shall be chrome plated brass with satin finish. Pair of flanges shall each consist of a wall mounting lug and a locking sleeve. One sleeve shall have locking screw to prevent rod rotation (rod ordered separately). Mounting lugs shall be provided with two (2) mounting holes to accept #10 round or pan head screws (furnished by others).

Round Concealed Screw Shower Rod Flanges shall be Model S-SH-2 as manufactured by Tubular Specialties Manufacturing, 13011 South Spring Street, Los Angeles, California 90061, tel 800-Grab Bar.



Order in conjunction with TSM Shower Rod Tubing, Stainless Steel or Aluminum as follows:

- S-106(49)** Stainless Steel Satin Finish, 1" O.D. x 18 gauge (25 x1.2mm)36", Lengths: 42", 48", 60", 72", 84", 96"
- S-106(49)/B** Stainless Steel Bright Finish, 1" O.D. x 18 gauge (25 x1.2mm)36", Lengths: 42", 48", 60", 72", 84", 96"
- S-1060(22)/B** Stainless Steel Slotted Tubing Bright Finish, 1" x 28 ga. (25 x.4mm), Length: 60" (includes 13 Hooks)
- S-106(15)/A** Aluminum Mill Finish Tubing, 1" x 28 ga. (25x.4mm), Length: 60"



Installation

1. Shower rod flanges are surface mounted. In-wall backing is recommended in accordance with local building codes. If intended for a prefabricated shower or bathtub, it is recommended that secure and appropriate backing be provided by the shower stall or bathtub manufacturer.
2. For standard 72" (1829mm) long shower curtains, install flanges at 74 1/2" (1892mm) rod centerline above finish floor or 67" (1702mm) above tub rim to result in a 6" (152mm) bottom overlap.
3. It is the installer's responsibility to select fasteners that are appropriate for the wall condition and application. Mounting lugs have 2 mounting holes for #10 round or pan head screws (furnished by installer).
4. Accessories should be inspected periodically to make sure their attachment to the wall is not loosening.

Manufacturer reserves the right to alter design or dimensions without formal notice and without incurring obligation.

© 2007, Tubular Specialties Mfg., Inc. All Rights Reserved



Guarantee

TSM S-SH-2 Round Concealed Screw Shower Rod Flanges are guaranteed against defects in workmanship and material for one year from shipping date.