



Since 1966

Tubular Specialties Manufacturing, Inc.

13011 South Spring Street, Los Angeles, CA 90061-1685

Phone 800/CALL TSM (800/225-5876) or 310/515-4801

online www.grabbar.com • Fax 310/217-0653

H/CS-1

1 1/2" O.D. Stainless Steel Grab Bars Round Concealed Screw Flanges

Technical Data

Revised July 2001

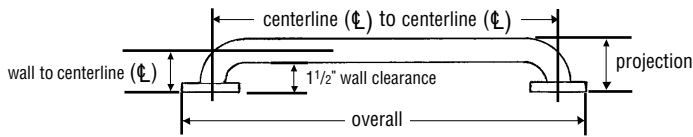

H/CS-1 grab bar shown with powdercoating in almond, one of several optional finishes available.

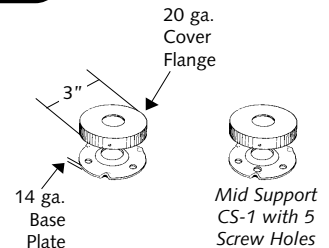

Design Considerations

- TSM originated the snap-lock flange concept, which is a direct-to-wall design that is an improvement in strength, cost and ease of installation over set screw fastening systems.
- H stands for 'half' and represents 1 1/2" O.D tubing. It is a heavy-duty tubing that serves the dual purpose of providing either a handhold or, if preferred, a 'shelf' to lean upon. H meets or exceeds all building codes.
- The standard wall tubing for grab bars is 18 gauge. However, 16 gauge tubing can be specified for extremely heavy duty applications; add (65) to the model number.
- It is recommended that bars or railings for marine, pool or spa applications be specified in a bright polished finish to resist oxidation. Type 316 stainless steel is also available for extra

protection against oxidation.

- TSM bars include 2" #10 stainless steel screws (51x5mm), which is important for two reasons:
 1. Strength: As stainless steel screws are very strong, they ensure the integrity of the bar.
 2. Rust-resistance: Many bars are installed in wet or damp areas, and stainless steel screws prevent unsightly rust from forming and spreading to the flange, then trickling down the wall.
- The effectiveness of grab bars as safety accessories depends entirely on a secure installation. All TSM grab bars exceed U.S. established guidelines for strength, but it is the responsibility of the design/build/install team to evaluate the specific wall conditions to determine the appropriate fasteners.
- Please check with local building inspectors for jurisdiction regarding codes affecting tubing O.D., etc.

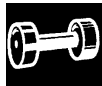

Strength

H/CS-1 Grab Bars support a 250 pound (114Kg) load when properly installed. *Caution:* A grab bar is only as strong as its anchoring devices

and the wall on which it is mounted. Grab bars should be inspected periodically to make sure their attachment to the wall is not loosening.



Suggested Architectural Specification

#H/CS-1 Series Grab Bars from TSM.

Tubular Specialties Manufacturing, Inc., Los Angeles, California, 800/Grab Bar (800/472-2227).

Material: Stainless steel type 304 (18-8), all welded construction.

Finish: [#4 Satin] [#8 Bright] [Powdercoated in _____ (color choice)] [Plated in _____ (plating choice)].

Gripping Surface: [Smooth] [Peened] [Knurled] [Ripple Grip™] [Anti-Slip] [Ripple Grip™ with Anti-Slip].

Tubing: 1 1/2" x 18 gauge (38x1.2mm) with ends turned 90° by mandrel bending and heliarc welded to flanges to form a single structural unit. Wall clearance 1 1/2" (38mm).

Flanges: Concealed snap-lock design with three screws per flange. 3" (76mm) round, 14 gauge base and 20 gauge cover (1.9x.9mm).

Installation Hardware: 2" #10 (51x5mm) stainless steel screws.

Strength: Supports a 250 pound (114Kg) load when properly installed.



Installation

1. Grab bar is surface mounted at locations marked by an "S". In-wall backing is required in accordance with local building codes. If intended for a prefabricated shower or bathtub, secure and appropriate backing must be provided by the shower stall or bathtub manufacturer.
2. While local codes must be complied with in mounting grab bars, the generally recommended height is 33" above floor level. Use

grab bar as a template to pinpoint mounting hole placement.

3. While TSM provides stainless steel screws with each grab bar, it is the installer's responsibility to select fasteners that are appropriate for the wall condition and application. Mounting holes are 1/4" diameter (6mm).
4. After mounting grab bar base flange securely onto wall, position locking dimples on cover flange over upsets on base flange and snap into place.
5. Accessories should be inspected periodically to make sure their attachment to the wall is not loosening.

Finish and Gripping Surface Series Numbers

FINISHES

Satin: The standard finish, also known as #4 brushed finish, US 32D or BHMA 630.

Bright: A look that is similar to chrome, also known as #8 polished finish, US 32 or BHMA 629.

Powdercoated: Colors: White, Almond, Biscuit, Parchment, Light Mocha, Taupe, Rosy Taupe, Wheat, Palomino, Sun Gold, Nutmeg, Vanilla, Navy, Slate Blue, Gray, Seafoam Green, Forest Green, Verdigris, Turquoise, Pink, Red, Black.

Plated: All plated products have a clear baked enamel finish. Colors: Bright Brass, Satin Brass, Antique Brass, Antique Bronze, Satin Bronze, Black Nickel, Satin Nickel, Bright Copper, Bright Gold (24K), Satin Gold (24K).

GRIPPING SURFACES

Smooth

Peening: Texture is achieved with metallic balls shot with high pressure air jet on the surface of the tubing, which produces slight indentations.

Knurling: Cuts a diamond-shaped crosshatch onto the surface of the bar. Provides excellent slip resistance, but soap residue must be cleaned regularly out of the grooves so that they do not become slippery.

Ripple Grip™: Bubble pattern embossed into the tubing. Attractive in the standard satin finish or the mirror bright finish and also combines well with powdercoating or plating.

Anti-Slip: Non-slip coating applied to the surface of the bar. Has a similar appearance to peening but has more of a gritty feel. Peening, knurling and Ripple Grip™ are all integral to the tubing itself; Anti-Slip is a coating that is applied over the tubing.

Ripple Grip™/Anti-Slip: Ripple Grip™ can be specified with Anti-Slip for a more pronounced non-slip surface. Anti-Slip and Ripple Grip™ are the only non-slip surfaces available with powdercoated and plated finishes. (Anti-Slip is applied *over* the powdercoating or plating and Ripple Grip™ is *under* the powdercoating or plating.)

Gripping Surface

	SMOOTH	PEENED	KNURLED	RIPPLE GRIP™	ANTI-SLIP	RIPPLE GRIP™ & ANTI-SLIP	
FINISH	SATIN	<input type="checkbox"/> H/CS-1 Entire bar has smooth, satin finish.	<input type="checkbox"/> H/CS-1/P Gripping surfaces are peened. Tubing ends and flanges are satin.	<input type="checkbox"/> H/CS-1/K Gripping surfaces are peened. Tubing ends and flanges are satin.	<input type="checkbox"/> H/CS-1/RG Tubing is satin finish Ripple Grip™. Flanges are satin.	<input type="checkbox"/> H/CS-1/ASLP Gripping surface is Anti-Slip. Tubing ends and flanges are satin.	<input type="checkbox"/> H/CS-1/RG/ASLP Tubing is Ripple Grip™ with Anti-Slip applied over gripping surface. Tubing ends and flanges are satin.
	BRIGHT	<input type="checkbox"/> H/CS-1/B Entire bar has mirror bright, smooth finish.	<input type="checkbox"/> H/CS-1/B/P Gripping surfaces are peened. Tubing ends and flanges are mirror bright.	<input type="checkbox"/> H/CS-1/B/K Gripping surfaces are knurled. Tubing ends and flanges are mirror bright.	<input type="checkbox"/> H/CS-1/B/RG Tubing is mirror bright finish Ripple Grip™. Flanges are mirror bright.	<input type="checkbox"/> H/CS-1/B/ASLP Gripping surface is Anti-Slip. Tubing ends and flanges are bright.	<input type="checkbox"/> H/CS-1/B/RG/ASLP Tubing is Ripple Grip™ with Anti-Slip applied over gripping surface. Tubing ends and flanges are mirror bright.
	POWDERCOATED	<input type="checkbox"/> H/CS-1/POWD Entire bar has smooth powdercoated finish. Powdercoated Color: _____	N/A	N/A	<input type="checkbox"/> H/CS-1/POWD/RG Entire bar has powdercoated finish. Tubing is Ripple Grip™. Powdercoated Color: _____	<input type="checkbox"/> H/CS-1/POWD/ASLP Entire bar has powdercoated finish. Gripping surface is Anti-Slip, which is applied over the powdercoated finish. Powdercoated Color: _____	<input type="checkbox"/> H/CS-1/POWD/RG/ASLP Entire bar has powdercoated finish. Tubing is Ripple Grip™ with Anti-Slip applied over the powdercoated finish. Powdercoated Color: _____
	PLATED	<input type="checkbox"/> H/CS-1/PLAT Entire bar has smooth plated finish. Plated Color: _____	N/A	<input type="checkbox"/> H/CS-1/PLAT/K Entire bar has plated finish. Gripping surfaces are knurled. Plated Color: _____	<input type="checkbox"/> H/CS-1/PLAT/RG Entire bar has plated finish. Tubing is Ripple Grip™. Plated Color: _____	<input type="checkbox"/> H/CS-1/PLAT/ASLP Entire bar has plated finish. Gripping surface is Anti-Slip, which is applied over the plating. Plated Color: _____	<input type="checkbox"/> H/CS-1/POWD/RG/ASLP Entire bar has plated finish. Tubing is Ripple Grip™ with Anti-Slip applied over the plated finish. Plated Color: _____

Add to Chosen Series for Complete Model Number

Tubular Specialties Manufacturing, Inc.
13011 South Spring Street, Los Angeles, CA 90061-1685
Phone 800/GRABBAR (800/472-2227) or 310/515-4801
online www.grabbar.com • Fax 310/217-0653

Basic Straight Bar

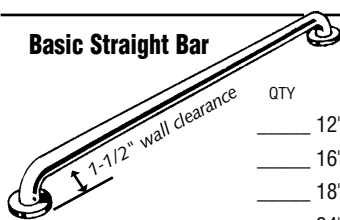

QTY	_____	32"
_____	12"	36"
_____	16"	40"
_____	18"	42"
_____	24"	48"
_____	30"	52"

"M" Adds a Mid Support

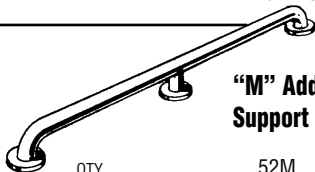

QTY	_____	52M	_____	84M
_____	36M	54M	_____	96M
_____	42M	60M	_____	108M
_____	48M	72M	_____	

"CM" is a Corner Mount

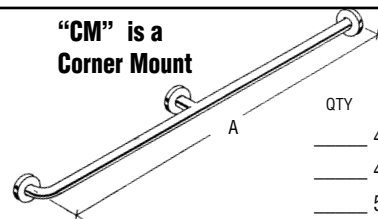

QTY	_____	42CM
_____		48CM
_____		52CM
_____		54CM

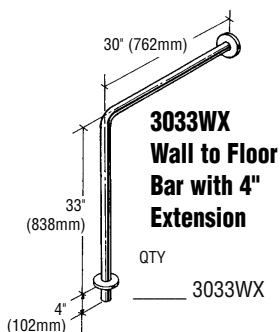

3033WX Wall to Floor Bar with 4" Extension

QTY _____ 3033WX

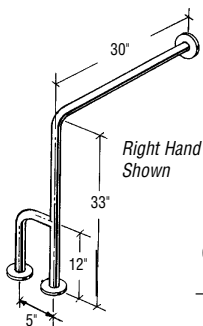

3033 Wall to Floor Bar with Outrigger

QTY _____ 3033, LH
_____ 3033, RH



Left Hand Shown

3033D Wall to Floor Bar with Double Outrigger

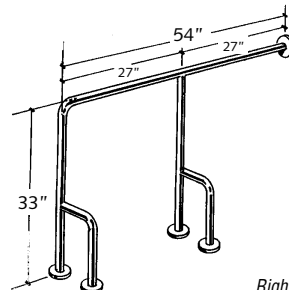

Left Hand Shown

QTY _____ 3033D, LH
_____ 3033D, RH

Right Hand Shown

Or create your own size: Q-3033WXM/CS-1 @ _____ horizontal (max 42") x _____ vertical (max 42")
(List horizontal dimension first) Q-3033M/CS-1 @ _____ horizontal (max 42") x _____ vertical (max 42")
Q-3033DM/CS-1 @ _____ horizontal (max 72") x _____ vertical (max 42")

832 Hockey Stick

Right Hand Shown

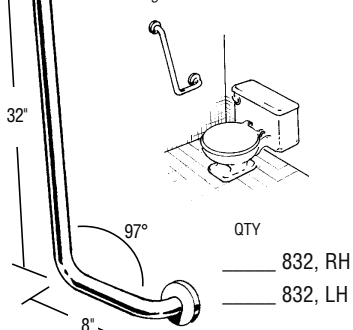

QTY _____ 832, RH
_____ 832, LH

2020 Combination Grab Bar

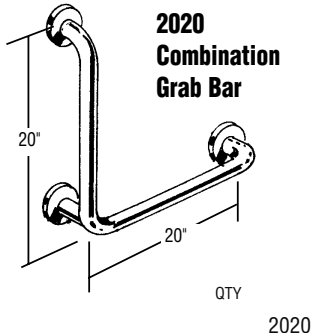

QTY _____ 2020

1220 Boomerang Bar

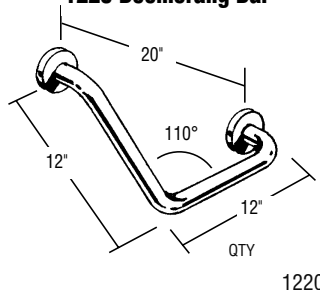

QTY _____ 1220

1220T Boomerang Bar with Center Support

Right Hand Shown

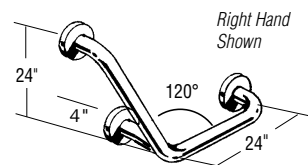

QTY _____ 1220T, RH
_____ 1220T, LH

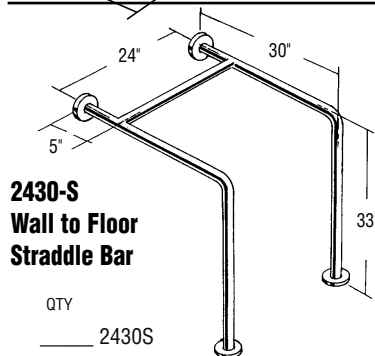

2430-S Wall to Floor Straddle Bar

QTY _____ 2430S

2228-S Floor Mounted Straddle Bar

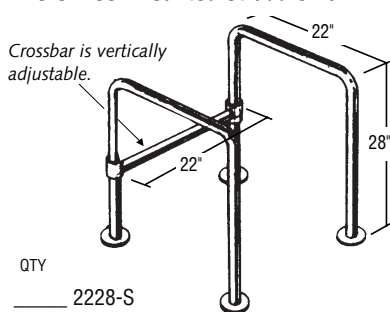

Crossbar is vertically adjustable.

QTY _____ 2228-S

1632 Horizontal/Vertical Bar

1632M @ 12" x 24"
1632M @ 18" x 32"
1632M @ 24" x 36"
1632M @ 24" x 48"

Or create your own size:
1632M @ _____ H _____ V
(List horizontal dimension first.)

QTY _____ 1632M @ _____ H x _____ V, RH
_____ 1632M @ _____ H x _____ V, LH

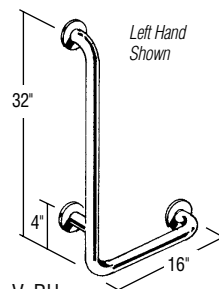

Left Hand Shown

2424-S Straddle Bar

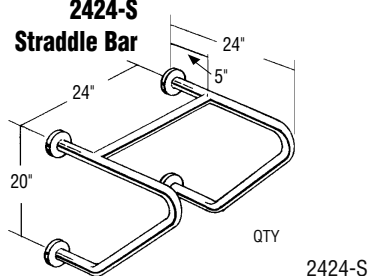

QTY _____ 2424-S

2424-SF Straddle Bar for Flush Valve

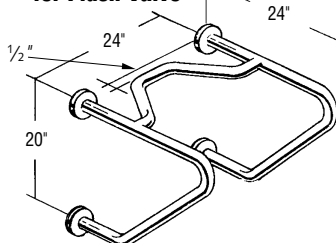

QTY _____ 2424-SF

2424-SN Straddle Bar for Tank Toilet

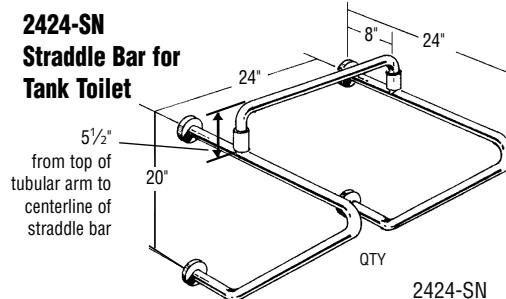

5 1/2" from top of tubular arm to centerline of straddle bar

QTY _____ 2424-SN

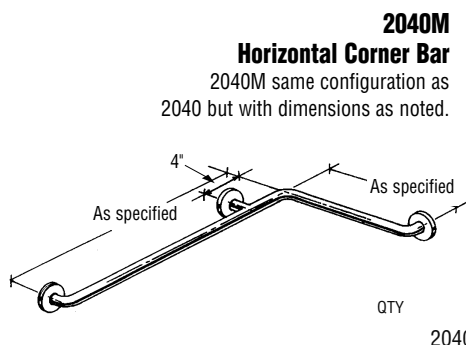
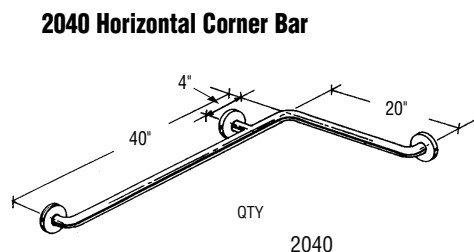
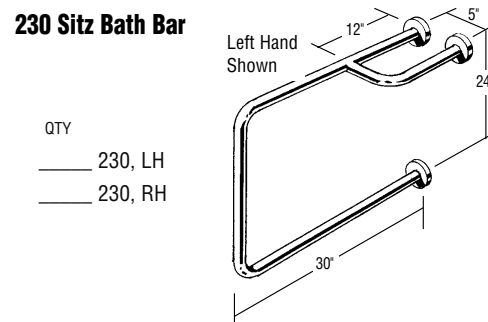
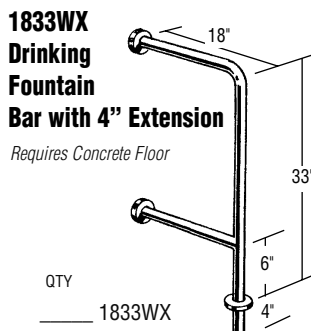
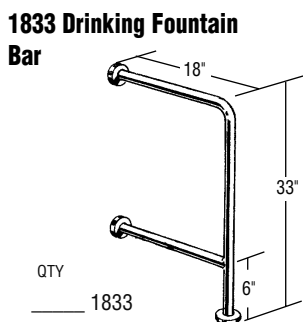
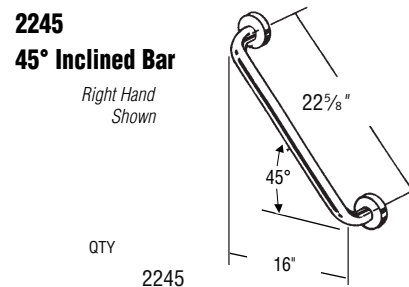
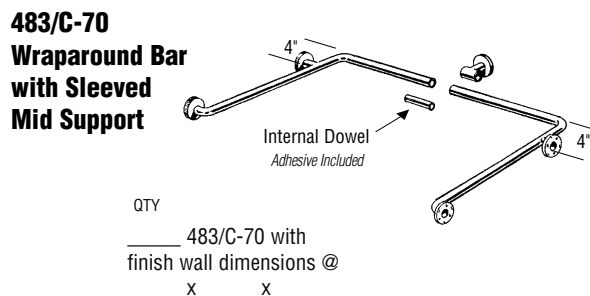
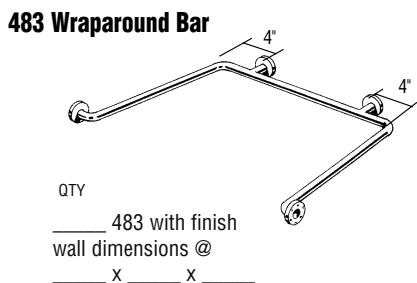
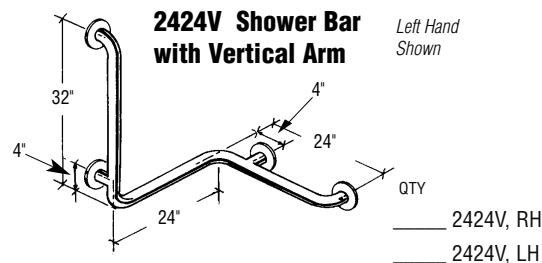
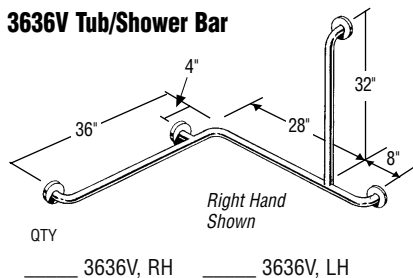
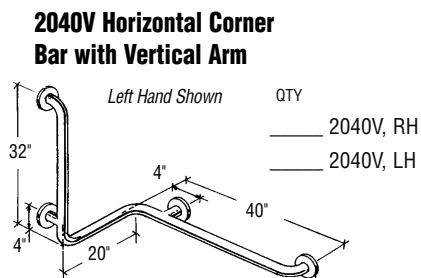
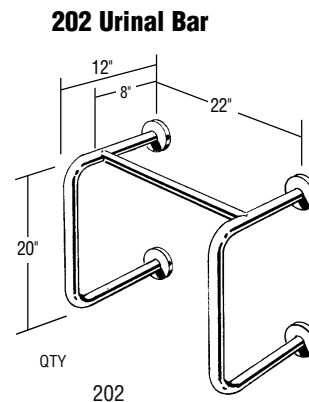
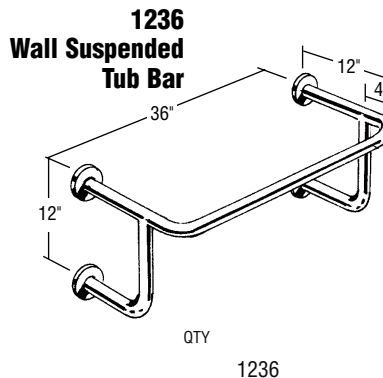
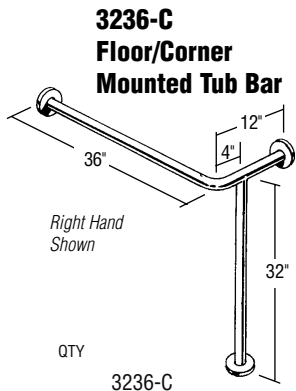
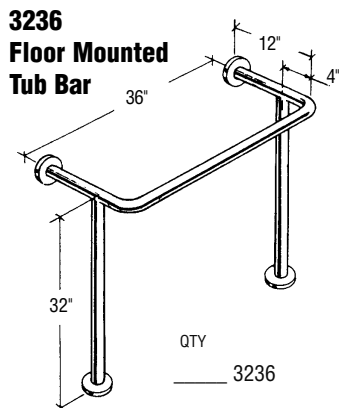

2040M @ 16" x 31"
 2040M @ 24" x 24"
 2040M @ 24" x 36"
 2040M @ 36" x 48"
 2040M @ 36" x 52"
 2040M @ 36" x 54"
 2040M @ 42" x 52"
 Or create your own size:
 2040M @ _____ x _____