



Since 1966

Tubular Specialties Manufacturing, Inc.

13011 South Spring Street, Los Angeles, CA 90061-1685

Phone 800/Grab Bar (800/472-2227) or 310/515-4801

www.GrabBar.com • Fax 310/217-0653

846

Technical Data

Revised October 2008

Folding Utility Shelf

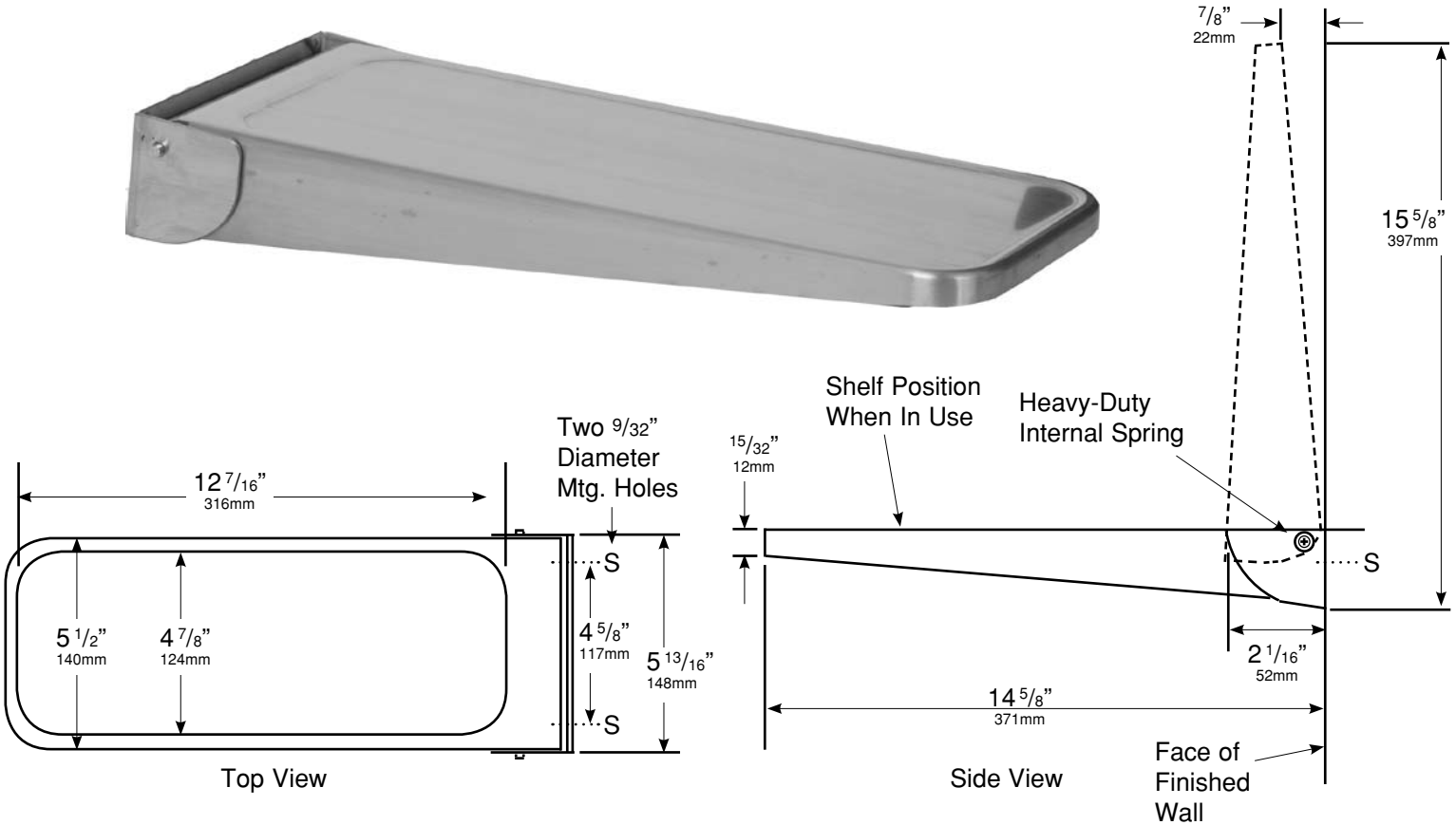

Specification

Folding Utility Shelf shall be satin finish stainless steel type 304 (18-8) 18 gauge with welded construction. Shelf shall automatically return to upright position when not in use via heavy-duty internal spring.

Folding Utility Shelf Model 846 as manufactured by Tubular Specialties Manufacturing, 13011 South Spring Street, Los Angeles, California 90061, tel 800-Grab Bar.



Installation

- Unit is surface mounted on wall or toilet partition adjacent to compartment at locations marked by an "S".
- Recommended mounting height from finish floor to centerline of shelf is 60" (1524mm).
- Allow 5" (127mm) minimum clearance between inside of door to front edge of shelf to facilitate door swinging open and closed.
- Allow 15" (381mm) clearance above screw holes for shelf to swing up.
- It is the installer's responsibility to select fasteners that are appropriate for the wall of partition condition and application.
- Accessories should be inspected periodically to make sure their attachment to the wall is not loosening.

Manufacturer reserves the right to alter design or dimensions without formal notice and without incurring obligation.

© 2008, Tubular Specialties Mfg., Inc. All Rights Reserved



Guarantee

TSM 846 Folding Utility Shelf is guaranteed against defects in workmanship and material for one year from shipping date.