



## Tubular Specialties Manufacturing, Inc.

13011 South Spring Street, Los Angeles, CA 90061-1685

Phone 800/Grab Bar (800/472-2227) or 310/515-4801

www.GrabBar.com • Fax 310/217-0653

# 736-PHI2

## Folding 4-Legged Shower/Dressing Area Seat Ivory Phenolic One-Piece Top

### Technical Data

Revised January 2009

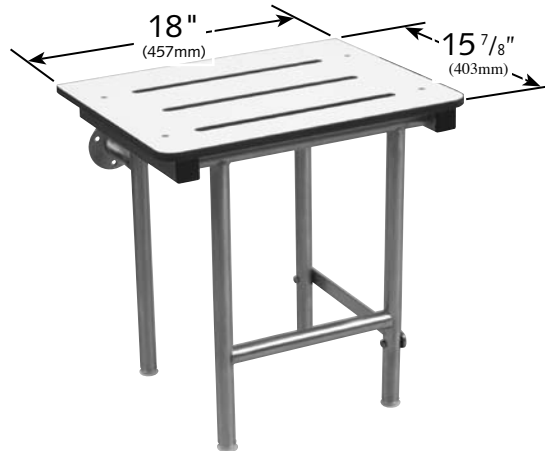

### Specification

TSM Model 736-PHI2 Folding 4-Legged Shower/Dressing Area Seat shall be stainless steel satin finish type 304 (18-8). Frame shall be 1<sup>1</sup>/<sub>4</sub>" x 18 gauge square tubing (32x1.2mm) with cross members of 1" x 18 gauge round tubing (25x1.2mm). Swing-down legs shall be 1" x 18 gauge round tubing (25x1.2mm). Mounting flanges (2) shall be 8 gauge round 3" (4.2x76mm) diameter with three mounting holes. Underslung hinge supports shall be 1" x 18 ga. with 1<sup>1</sup>/<sub>4</sub>" x 12 gauge sleeves. Seat shall be one-piece phenolic top 1/2" (13mm) thick. Phenolic top

shall be solidly-fused plastic laminate 1/2" thick (13mm) with matte-finish melamine surface, ivory colored face sheet and integrally bonded black phenolic resin core. Top shall be bolted to frame with countersunk stainless steel machine screws and cap nuts.

**Folding 4-Legged Shower/Dressing Area Seat shall be Model 736-PHI2 as manufactured by Tubular Specialties Manufacturing, 13011 South Spring Street, Los Angeles, California 90061, tel 800-Grab Bar.**



### Operation

Seat is manually lifted to up position or lowered to horizontal sitting position using the "H" cross member.

Seat remains in up position until lowered.



### Installation

1. The 733-PHI2 is manufactured to hold 250 pounds (113.5Kg), but it is only as strong as the integrity of the wall and the installation method provided by the installer.
2. In-wall backing is required. If the shower is prefabricated, secure and appropriate backing must be provided by the shower stall manufacturer.
3. Seat is surface mounted to wall through in-wall backing with two mounting flanges. Legs rest on floor when seat is in horizontal position. While local codes must be complied with in mounting seat, the recommended seat height is 18" (457mm) above floor level. The template that is supplied with

each seat will allow you to mount the seat at that height.

4. Mount holes from finished floor at 12<sup>1</sup>/<sub>4</sub>" and 14" (311 & 356mm).
5. It is the installer's responsibility to select fasteners that are appropriate for the wall or partition condition and application. TSM does not include fasteners with shower or tub seats.
6. Accessories should be inspected periodically to make sure their attachment to the wall is not loosening.

