



Tubular Specialties Manufacturing, Inc.

13011 South Spring Street, Los Angeles, CA 90061-1685

Phone 800/CALL TSM (800/225-5876) or 310/515-4801

www.GrabBar.com • Fax 310/217-0653

733-A

**Folding Wheelchair Transfer Seat
Naugahyde Cushion**

Technical Data

Revised October 2008

Page 1 of 2



Model 733-A, Left Hand



Model 733-A, Right Hand



Folded Up Against Wall

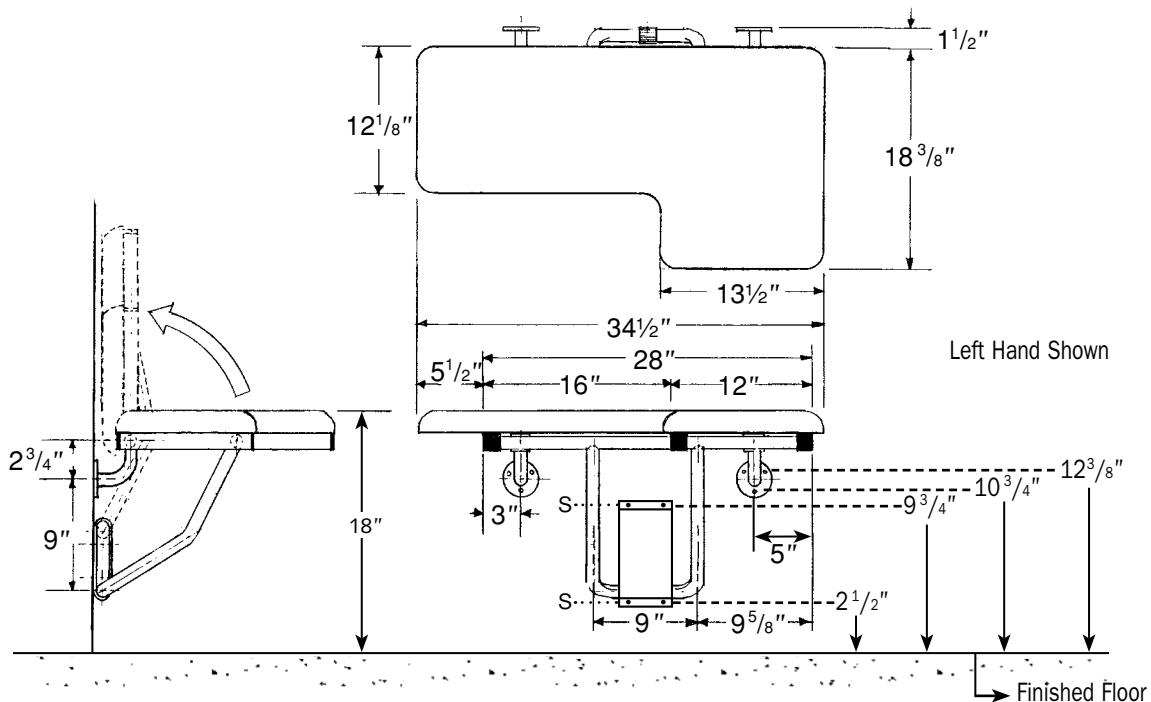



Model Numbers

- 733-A, RH White Cushion, Right Hand
- 733-A, LH White Cushion, Left Hand
- 733-A/CC, RH Colored Cushion, Right Hand
- 733-A/CC, LH Colored Cushion, Left Hand

/CC Cushion Color Options

Almond, Parchment, Light Mocha, Taupe, Rosy Taupe, Wheat, Nutmeg, Vanilla, Navy, Slate Blue, Gray, Dark Seafoam Green, Forest Green, Verdigris, Turquoise, Light Pink, Red, Black.



Specification

Folding Wheelchair Transfer Seat shall have a frame constructed of type 304, satin finish stainless steel of 18 gauge (1.2mm) 1 1/4" (32mm) square tubing and 18 gauge (1.2mm) 1" (25mm) diameter seamless tubing. Shower seat shall be equipped with two (2) 3" (76mm) diameter mounting flanges of stainless steel satin finish type 304 (18-8) 8 gauge (4.2mm) with three (3) 1/4" (6mm) mounting holes. Guide bracket shall be 16 gauge (1.6mm) stainless steel type 304 (18-8), formed construction with two (2) 1/4" mounting holes. Seat shall be naugahyde white cushion

covering 2 1/2" (64mm) thick foam rubber. Seat shall be able to lock in upright position when not in use. Handing shall be [right] [left]. Shower seat shall comply with barrier-free accessibility guidelines, including ADAAG in U.S.A.

Folding Wheelchair Transfer Seat shall be Model 733-A as manufactured by Tubular Specialties Manufacturing, 13011 South Spring Street, Los Angeles, California 90061, tel 800-Grab Bar.



Operation

The Folding Wheelchair Transfer Seat complies with the Americans with Disabilities Act (ADA) for use in a 36" x 36" shower stall. The seat's distinctive shape allows the user to transfer from a wheelchair to the narrow part of the seat and slide across to the wide section which is installed at the corner of the stall. Grab bars should be specified in conjunction with all shower seats.

The guide bracket supports U-shaped legs which move freely up and down, allowing user to lower the seat to sitting position or fold against the wall, and is held in place by clip with spring action. The spring at the top of the base plate holds the seat in an upright position. When seat is pulled down, legs are released from the spring and the seat folds down into sitting position. *Note:* TSM also offers a similar seat with a counterbalance mechanism that offers resistance when the seat is lowered. If this feature is desired, specify 731 instead of 733.



Installation

1. The 733-A is manufactured to meet and exceed ADAAG requirements as published in ANSI A117.1-1986 and CFR 28 part 36, Federal Register Vol. 56 #144, July 26, 1991, section 4.21.3 and section 4.26.3 that the fabricated product shall be of adequate strength to support a load of 250 pounds (113.4kg). Having said this, the seat is only as strong as the mounting surface to which it is attached. Consult local codes to assure compliance.
2. In-wall backing is required. If the shower is prefabricated, secure and appropriate backing must be provided by the shower stall manufacturer.
3. Seat is surface mounted to wall through in-wall backing with two mounting flanges at top and guide bracket below. While

local codes must be complied with in mounting seat, the recommended seat height is 18" (457mm) above floor level. The template that is supplied with each seat will allow you to mount the seat at that height with mounting holes from finished floor for model at 2 1/2" & 9 3/4" for guide bracket and 10 3/4" & 12 3/8" for flanges.

4. The horizontal section of the U-shaped legs must be positioned in-between the base plate and cover guide bracket before seat is secured to wall.
5. It is the installer's responsibility to select fasteners that are appropriate for the wall condition and application; TSM does not include fasteners with shower or tub seats.

