



**Tubular Specialties Manufacturing, Inc.**  
 13011 South Spring Street, Los Angeles, CA 90061-1685  
 Phone 800/Grab Bar (800/472-2227) or 310/515-4801  
 www.GrabBar.com • Fax 310/217-0653

**730-A**

**Shower/Dressing Area Seat**  
 Naugahyde Cushion

**Technical Data**

Revised Oct. 2008

Page One of Two



Folded Up Against Wall

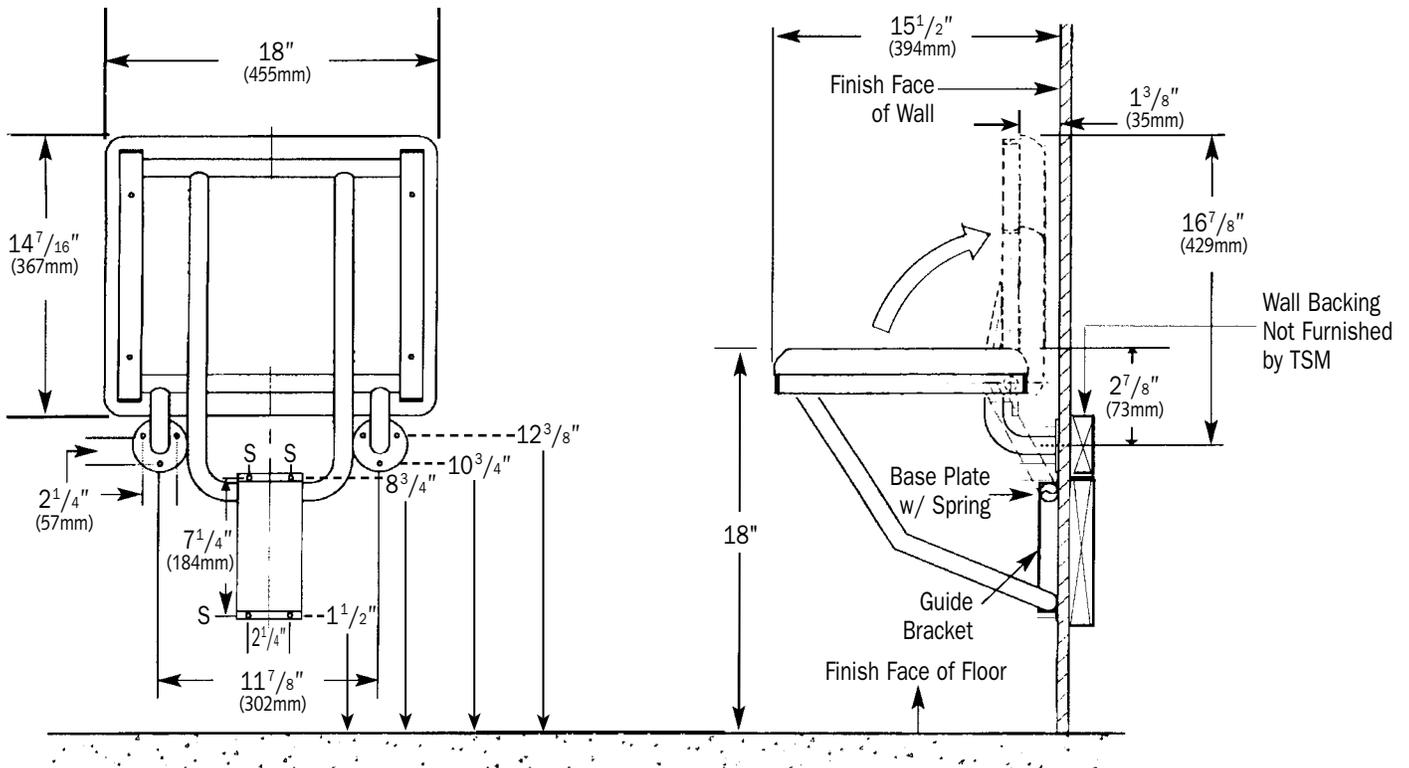

TSM 730-A Shower/Dressing Area Seat is guaranteed against defects in workmanship and material for one year from shipping date.



## Specification

Folding Shower/Dressing Area Seat shall have a frame constructed of type 304, satin finish stainless steel of 18 gauge (1.2mm) 1¼" (32mm) square tubing and 18 gauge (1.2mm) 1" (25mm) diameter seamless tubing. Shower seat shall be equipped with two 3" (76mm) diameter mounting flanges of stainless steel satin finish type 304 (18-8) 8 gauge (4.2mm) with three ¼" (6mm) mounting holes; a guide bracket of 16 gauge (1.6mm) stainless steel type 304 (18-8), formed construction with four ¼" mounting holes; and a spring of 24 gauge (0.6mm) stainless steel type 304 (18-8) shall be spot

welded to heavy gauge stainless steel base plate. Seat cushion shall be white naugahyde cushion (water-resistant reinforced vinyl fabric) mounted on ½" (13mm) thick plywood and 2½" (64mm) thick foam padding. Seat shall be able to lock in upright position when not in use. Shower seat shall comply with barrier-free accessibility guidelines (including ADAAG in U.S.A.).

**Shower/Dressing Area Seat shall be Model 730-A as manufactured by Tubular Specialties Manufacturing, 13011 South Spring Street, Los Angeles, California 90061, tel 800-Grab Bar.**



## Operation

The guide bracket supports U-shaped legs which move freely up and down, allowing user to lower the seat to sitting position or fold against the wall, and is held in place by clip with spring action. The spring at the top of the base plate holds

the seat in an upright position. When seat is pulled down, legs are released from the spring and the seat folds down into sitting position. Grab bars should be specified in conjunction with all shower seats.



## Installation

1. The 730-A is manufactured to meet and exceed ADAAG requirements as published in ANSI A117.1-1986 and CFR 28 part 36, Federal Register Vol. 56 #144, July 26, 1991, section 4.21.3 and section 4.26.3 that the fabricated product shall be of adequate strength to support a load of 250 pounds (113.4kg). Having said this, the seat is only as strong as the mounting surface to which it is attached. Consult local codes to assure compliance.
2. In-wall backing is required. If the shower is prefabricated, secure and appropriate backing must be provided by the shower stall manufacturer.
3. Seat is surface mounted to wall through in-wall backing with two mounting flanges at top and guide bracket below. While local codes must be complied with in mounting seat, the recommended seat height is 18" (457mm) above floor level. The template that is supplied with each seat will allow you to mount the seat at that height with mounting holes from finished floor for model at 1½" & 8¾" for guide bracket and 10¾" & 12-3/8" for flanges.
4. The horizontal section of the U-shaped legs must be positioned in-between the base plate and cover guide bracket before seat is secured to wall.
5. It is the installer's responsibility to select fasteners that are appropriate for the wall condition and application; TSM does not include fasteners with shower or tub seats.



**Guarantee**

TSM 730-A Shower/Dressing Area Seat is guaranteed against defects in workmanship and material for one year from shipping date.