



# Tubular Specialties Manufacturing, Inc.

13011 South Spring Street, Los Angeles, CA 90061-1685  
 Phone 800/Grab Bar (800/472-2227) or 310/515-4801  
 www.GrabBar.com • Fax 310/217-0653

# 5203

## Technical Data

Revised April 2005

# Recessed Waste Receptacle

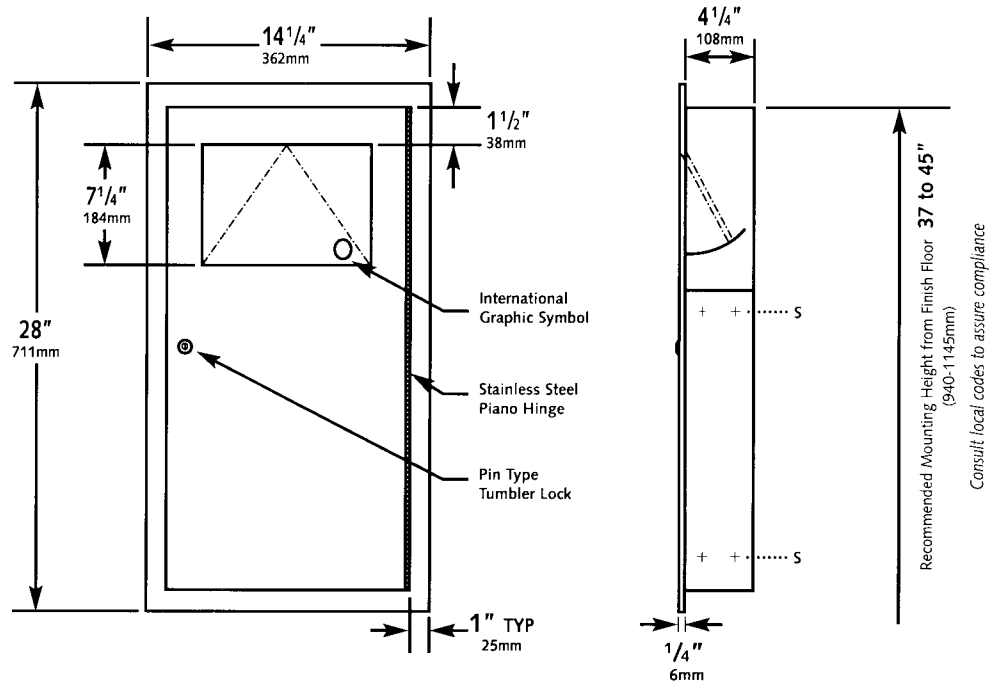
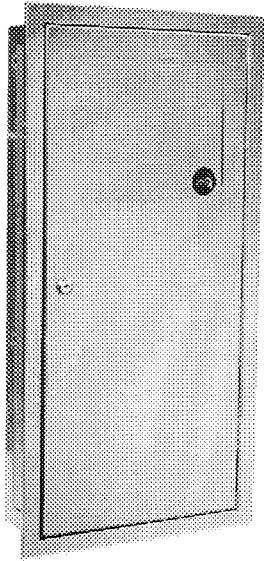

### Specification

Recessed Waste Receptacle shall have a waste capacity of 3 gallons (11.4 liters) and shall be fabricated of type 304 satin finish stainless steel alloy 18-8, 22 gauge (.7mm). Door shall be secured to cabinet with a full-length 3/16" (5mm) dia. multi-staked stainless steel piano hinge and shall be held closed with a tumbler lock keyed like other TSM washroom accessories. Push door shall be equipped with an international graphic symbol identifying

waste disposal. Structural assembly of all components shall be of welded construction and flange shall be drawn, one-piece construction. Interior waste container shall be fabricated of 26 gauge (.5mm) stainless steel and shall be easily removable for maintenance.

**Recessed Waste Receptacle shall be Model 5203 as manufactured by Tubular Specialties Manufacturing, 13011 South Spring Street, Los Angeles, California 90061, tel (800)Grab Bar.**



### Operation

Users push self-closing door to deposit waste material. Waste receptacle is emptied by unlocking door and removing waste container.



### Materials/Workmanship

- Cabinet** Stainless steel type 304 (18-8) 22 gauge satin finish (0.8mm). All-welded construction.
- Door** Stainless steel type 304 (18-8) 18 gauge satin finish (1.2mm). Full-length welded 3/16" (5mm) dia. stainless steel piano hinge. Pin tumbler lock is keyed like other TSM accessories.
- Push Door** Stainless steel type 304 (18-8) 22 gauge satin finish (0.8mm). Secured to door with spring-loaded, full-length stainless steel piano hinge. Equipped with international graphic symbol identifying waste disposal.
- Waste Container** Stainless steel type 304 (18-8) 26 gauge (.5mm) 3 gallon (11.4 L) capacity.



### Installation

1. Recommended mounting height from finish floor to top of cabinet is 37" to 45" (940-1145mm). Consult local codes to assure compliance.
2. Provide framed wall opening 12 3/4" wide x 26 1/2" high (324x673mm) with a minimum recessed depth from finish face of wall of 4" (102mm). Note that top of RWO is 3/4" (19mm) below top of unit.
3. Position unit to avoid pipes, vents and conduits previously installed in wall.
4. After installing shims as required to give a solid base, use #10 self tapping screws supplied by manufacturer through concealed mounting holes provided.

Manufacturer reserves the right to alter design or dimensions without formal notice and without incurring obligation.

© 2005, Tubular Specialties Mfg., Inc. All Rights Reserved



TSM 5203 Recessed Waste Receptacle is guaranteed against defects in workmanship and material for one year from shipping date.