



Since 1966

# Tubular Specialties Manufacturing, Inc.

13011 South Spring Street, Los Angeles, CA 90061-1685

Phone 800/Grab Bar (800/472-2227) or 310/515-4801

www.GrabBar.com • Fax 310/217-0653

# 5200-D-12

## Technical Data

Revised April 2005

### Recessed Paper Towel Dispenser & Waste Receptacle, 7" Deep

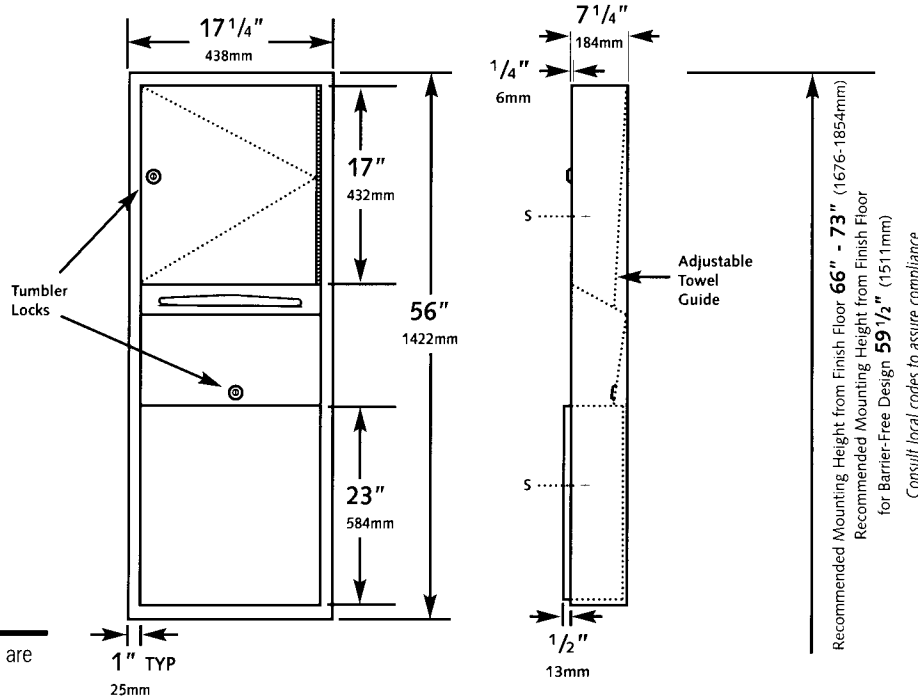
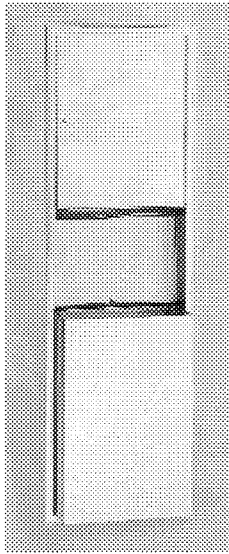

Recommended Mounting Height from Finish Floor **66" - 73"** (1676-1854mm)  
 Recommended Mounting Height from Finish Floor for Barrier-Free Design **59 1/2"** (1511mm)  
 Consult local codes to assure compliance



### Operation

Paper towels are dispensed through slot. Towels are replaced by unlocking door. Waste receptacle is emptied by unlocking from cabinet.



### Specification

Recessed Paper Towel Dispenser and Waste Receptacle shall be type 304 stainless steel, 22 gauge with exposed surfaces satin finish. Structural assembly of all components shall be of welded construction and flange shall be drawn, one-piece construction. Paper towel dispenser shall dispense 600 C-fold, 800 multi-fold or 1,100 single-fold paper towels. Adjustable guide shall be provided to allow dispensing of multi-fold or C-fold paper towels. Face trim shall be one-piece construction with no miters or welding and shall be 1" wide and have

1/4" square return to wall. Cabinet shall have no exposed fastening devices or spot welded seams. Dispenser door shall be double pan construction with No-Flex core and shall be mounted to cabinet body on a 3/16" dia. heavy-duty stainless multi-staked piano hinge. Dispenser door and waste container shall have tumbler locks keyed alike to other TSM equipment. Removable waste receptacle shall have a capacity of 12 gallons (46 L).

**Recessed Paper Towel Dispenser and Waste Receptacle, 7" Deep shall be Model 5200-D-12 as manufactured by Tubular Specialties Manufacturing, 13011 South Spring Street, Los Angeles, California 90061, tel (800)Grab Bar.**



### Materials

- Cabinet** Stainless steel type 304 (18-8) 22 gauge satin finish (0.8mm). Flange is drawn, one-piece seamless construction with no mitered corners.
- Door** Stainless steel type 304 (18-8) 22 gauge satin finish with double panel construction and fiberboard filler. Full-length welded 3/16" (5mm) dia. stainless steel piano hinge. Pin tumbler lock is centered on door and keyed like other TSM accessories.
- Paper Towel Dispenser** Stainless steel type 304 (18-8) 22 gauge satin finish. Dispensing mouth has hemmed edge for safety. Capacity: 600 C-fold, 800 multi-fold or 1,100 single-fold paper towels.
- Waste Receptacle** Stainless steel type 304 (18-8) 22 gauge satin finish 12 gallon (46 L) capacity. Secures to cabinet with pin tumbler lock centered on door and keyed like other TSM accessories.



### Installation

- Recommended mounting height from finish floor to top of cabinet is 66" - 73" (1675-1855mm) standard and 59 1/2" (1510mm) for barrier-free design. Consult local codes to assure compliance.
- Provide framed wall opening 15 3/4" wide x 54 1/2" high (400x1384mm) with a minimum recessed depth from finish face of wall of 7 1/4" (184mm). Note that top of RWO is 3/4" (19mm) below top of unit.
- Position unit to avoid pipes, vents and conduits previously installed in wall.
- After installing shims as required to give a solid base, use #10 self tapping screws supplied by manufacturer through concealed mounting holes provided at points indicated by an "S".

Manufacturer reserves the right to alter design or dimensions without formal notice and without incurring obligation.

© 2005, Tubular Specialties Mfg., Inc. All Rights Reserved.



## Guarantee

TSM 5200-D-12 Recessed Paper Towel Dispenser is guaranteed against defects in workmanship and material for one year from shipping date.